



# H180T RIGID HAULAGE TRACTOR

4X4



**BUILT AFRICA TOUGH**

[machinesales@dezzi.co.za](mailto:machinesales@dezzi.co.za)

[www.dezzi.co.za](http://www.dezzi.co.za)



# H180T RIGID HAULAGE TRACTOR

## SPECIFICATION SHEET

\*Desmond Equipment SA (Pty) Ltd reserves the right to modify specifications without notice.

### ENGINE

MAKE : Cummins  
 MODEL : QSB 6.7 Turbo Intercooled  
 CAPACITY : 6.7 Liters  
 POWER : 240Hp (179KW) @ 2 500RPM  
 TORQUE : 987Nm @ 1 500RPM

### TRANSMISSION

MAKE : Allison  
 MODEL : 3000 World Series  
 GEARING : Full power shift  
 GEARS : Forward - 6  
 Reverse - 1  
 SPEED : 40Km/H  
 TORQUE CONVERTER : TC 411

### AXLES

FRONT : ITL SD 55 Drive  
 Pivoting steering axle  
 REAR : Rockwell PRC 673HD

### TYRES

	4x4 (1)	4x4 (2)
FRONT :	420 R24	420 R24
REAR :	650 R38	650 R42

### BRAKES

TYPE : S-Cam air brake  
 SIZE : 16.5" x 5" drum brake  
 PARK BRAKE : Spring applied with emergency failsafe

### STEERING

- Fully hydraulic orbital controlled steering with double-acting cylinder
- Full flow filtration
- Working pressure - 1500 Psi (10.3 Mpa)

### ELECTRICS

VOLTAGE : 12 Volt  
 BATTERY : 1 x 12 Volt sealed type  
 ALTERNATOR : 12 Volt / 70 Amp

### PNEUMATIC SYSTEM

CAPACITY : 40 Litres  
 WORKING PRESSURE : 120 Psi (8.1 Bar) Unloader valve controlled

### HYDRAULIC SYSTEM

OIL CAPACITY : 80 Liters  
 PUMPS : Fixed displacement gear driven  
 WORKING PRESSURE : 2 200 Psi (15.1 Mpa) Full flow filtration

### CAB

- Fully adjustable, weight compensating seat with built in suspension
- ROPS and FOPS certified
- Seat belt
- Cab light
- Fully enclosed & lockable
- Optional air-conditioning
- Cab access - side door, L/H side
- Windscreen wiper
- Roof mounted ventilation fan

### SERVICE CAPACITIES

COOLING SYSTEM : 32 Liters (50% Anti-freeze)  
 ENGINE CRANKCASE : 21 Liters  
 FRONT DIFFERENTIAL : 12 Liters  
 PLANETARY HUB : 2.5 Liters each end  
 REAR DIFFERENTIAL : 16 Liters  
 TRANSMISSION : 15 Liters  
 DIESEL TANK : 275 Liters / 350 Liters  
 HYDRAULIC SYSTEM : 80 Liters

### OPERATIONAL WEIGHTS

FRONT AXLE : 2 800kg - 3200kg  
 REAR AXLE : 4 790kg - 5 100kg  
 TOTAL TARE : 7 590kg - 8 300kg  
 GCM : 11 5 000kg (off highway use)

### OPTIONAL EQUIPMENT

- Cab heater
- Radio
- Engine monitoring system
- Custom painting
- Stainless steel exhaust
- Air conditioner

### HITCH

- Hydraulic cradle hitch with 90mm ball or LCM hitch
- Weight Transfer Hitch (Optional)

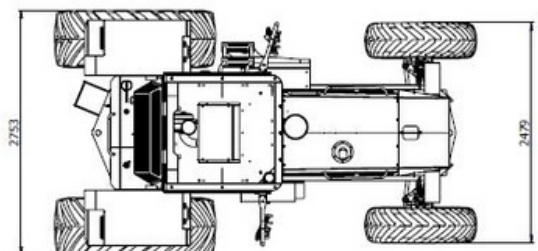
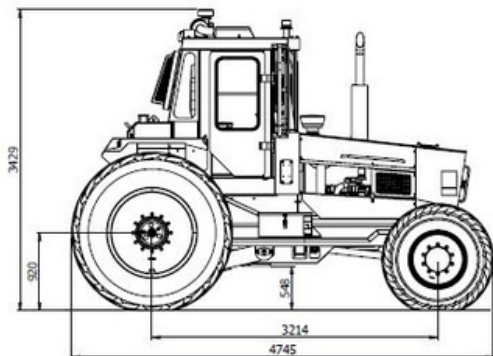

**BUILT AFRICA TOUGH**



**CALL : 0800 DEZZI / 33994**

Head Office: +27 (0)39-685 4100

Email: [machinesales@dezzi.co.za](mailto:machinesales@dezzi.co.za)

[www.dezzi.co.za](http://www.dezzi.co.za)