



H120T RIGID HAULAGE TRACTOR

4X4 | 4X2



BUILT AFRICA TOUGH

machinesales@dezzi.co.za

www.dezzi.co.za



H120T RIGID HAULAGE TRACTOR

SPECIFICATION SHEET

*Desmond Equipment SA (Pty) Ltd reserves the right to modify specifications without notice.

ENGINE

| | | |
|------------|--------------------------|---------------------------|
| MAKE : | Cummins | Cummins |
| MODEL : | 6 BT 5.9 Turbocharged | QSB 6.7 Turbo Intercooled |
| CAPACITY : | 5.9 Liters | 6.7 Liters |
| POWER : | 165Hp (123kW) @ 2 200RPM | 173Hp (129kW) @ 2 300RPM |
| TORQUE : | 640Nm @ 1 600RPM | 800Nm @ 1 500RPM |

TRANSMISSION

| | | |
|--------------------|----------------------------|----------------------------|
| MAKE : | Allison | JCB |
| MODEL : | 3000 World Series | PS 900 |
| GEARING : | Full power shift | Full power shift |
| GEARS : | Forward - 6 Reverse - 1 | Forward - 6 Reverse - 1 |
| SPEED : | 40Km/H | 40Km/H |
| TORQUE CONVERTER : | TC 411 | TC W300 |

AXLES

| | | |
|---------|--|---|
| | 4x2 | 4x4 |
| FRONT : | Dezzi non-drive with air ride suspension | ITL SD 55 Drive Pivoting steering axle |
| REAR : | Rockwell PRC 673P | Rockwell PRC 673P |

TYRES

| | | | |
|---------|-----------|---------|-----------------|
| | 4x2 | 4x4 | Forestry Logger |
| FRONT : | 10.5 x 16 | 380 R24 | 14.9 x 24 |
| REAR : | 20.8 R38 | 600 R38 | 20.8 x 38 |

BRAKES

TYPE : S-Cam air brake
 SIZE : 16.5" x 5" drum brake
 PARK BRAKE : Spring applied with emergency failsafe

STEERING

- Fully hydraulic orbital controlled steering with double-acting cylinder
- Full flow filtration
- Working pressure - 1500 Psi (10.3 Mpa)

ELECTRICS

VOLTAGE : 12 Volt
 BATTERY : 1 x 12 Volt sealed type
 ALTERNATOR : 12 Volt / 70 Amp

PNEUMATIC SYSTEM

CAPACITY : 20 Litres
 WORKING PRESSURE : 120 Psi (8.1 Bar) Unloader valve controlled

HYDRAULIC SYSTEM

OIL CAPACITY : 80 Liters
 PUMPS : Fixed displacement gear driven
 WORKING PRESSURE : 2 200 Psi (15.1 Mpa) Full flow filtration

CAB

- Fully adjustable, weight compensating seat with built in suspension
- ROPS and FOPS certified
- Seat belt
- Cab light
- Roof mounted ventilation fan
- Fully enclosed & lockable
- Cab access - side door, L/H side
- Windscreen wiper
- Optional air-conditioning

SERVICE CAPACITIES

| | |
|--------------------------|-----------------------------|
| COOLING SYSTEM : | 32 Liters (50% Anti-freeze) |
| ENGINE CRANKCASE : | 16 Liters |
| REAR AXLE DIFFERENTIAL : | 16 Liters |
| TRANSMISSION : | 15 Liters |
| DIESEL TANK : | 275 Liters / 350 Liters |
| HYDRAULIC SYSTEM : | 80 Liters |
| 4x4 | |
| FRONT DIFFERENTIAL : | 12 Liters |
| PLANETARY HUB : | 2.5 Liters each end |

OPERATIONAL WEIGHTS

| | |
|--------------|---------------------|
| FRONT AXLE : | 2 300kg - 2 500kg |
| REAR AXLE : | 4 600kg - 4 900kg |
| TOTAL TARE : | 6 900kg - 7 400kg |
| GCM : | 48 000kg - 56 000kg |

OPTIONAL EQUIPMENT

- Cab heater
- Radio/Tape
- Engine monitoring system
- Custom painting
- Stainless steel exhaust
- Air conditioner

HITCH

- Hydraulic cradle hitch with 90mm ball or LCM hitch
- Weight Transfer Hitch (Optional)

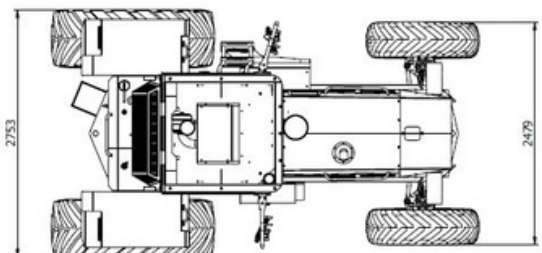
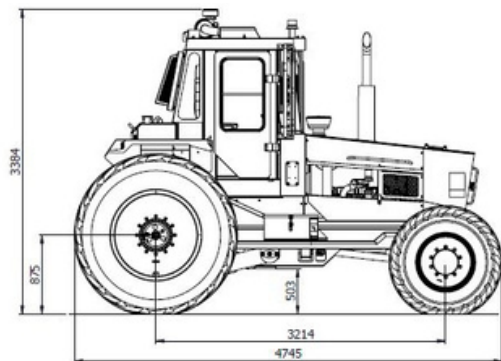

BUILT AFRICA TOUGH



CALL : 0800 DEZZI / 33994

Head Office: +27 (0)39-685 4100

Email: machinesales@dezzi.co.za

www.dezzi.co.za