



# DS120B CABLE SKIDDER

4X4



**BUILT AFRICA TOUGH**

[machinesales@dezzi.co.za](mailto:machinesales@dezzi.co.za)

[www.dezzi.co.za](http://www.dezzi.co.za)



# DS120B CABLE SKIDDER

## SPECIFICATION SHEET

\*Desmond Equipment SA (Pty) Ltd reserves the right to modify specifications without notice.

### ENGINE

TYPE : Cummins  
 MODEL : 6BT - 5.9 Turbocharged - FR90869 Tier 2  
 CAPACITY : 5.9 Litres  
 POWER : 165Hp (123KW) @ 2500 RPM  
 TORQUE : 609Nm @ 1600 RPM

### TRANSMISSION

TYPE : ZF  
 MODEL : 6WG160  
 GEARS : 5 Forward  
 3 Reverse  
 TORQUE CONVERTER : W300

### AXLES

FRONT : ZF MTS 3085 with limited slip  
 REAR : ZF MTS 3095 with diff lock

### TYRES

STANDARD TYRES : 23.1 x 26 Forestry Special

### BRAKES

#### SERVICE BRAKE

- Outboard, sealed, wet brakes activating all four wheels (max pressure 70 Bar)
- Back-up emergency stored system pressure for 15 full brake applications

#### PARK / EMERGENCY BRAKE

- Mechanically applied SAHR brake on front and rear axle (disc on pinion shaft both front & rear)
- Activated either via hand lever or emergency stop button

### STEERING

- Centre pivot - frame articulation
- Full hydraulic open circuit with dedicated separate hydraulic tank and drive pump
- Steering angle - 45° in each direction (Total 90°)

### ELECTRICS

VOLTAGE : 24 Volt  
 BATTERY : 2 X 12 Volt  
 ALTERNATOR : 24 Volt / 70 Amp

### CAB

- ROPS/FOPS Certified
- Rubber mounted tilting through 40°
- Fully adjustable suspension seat with arm rests
- Air-conditioned option or standard pressurised fan
- Soft joystick controls for both winch and blade functions

### SERVICE CAPACITIES

COOLING SYSTEM : 26 Litres (50% Anti-freeze)  
 ENGINE CRANKCASE : 14.8 Litres  
 DIFFERENTIALS : 28 Litres (per differential)  
 TRANSMISSION : 26 Litres  
 DIESEL TANK : 180 Litres  
 HYDRAULIC SYSTEM : 80 Litres (Steering)  
 140 Litres (Winch)

### OPERATIONAL WEIGHTS

OPERATING WEIGHTS : Front Axle - 6 600kg  
 Rear Axle - 5 100kg  
 Total - 11 700kg  
 (DS120T Standard Equipment)

### WINCH

- Allied WH400 hydraulic winch (40 000lb line pull)
- Counter rotation with drag brake and free spool. Operated via 4T joystick (no electronics)
- Standard Winch Speed @ 2200RPM = 55-60m/min

### WINCH HYDRAULICS

- Closed circuit design with radial piston pump
- System delivers 180 L/min @ 2200 RPM
- Winch system utilises its own dedicated hydraulic tank with a high pressure filter located on pressure delivery for protection in case of hydraulic pump failure

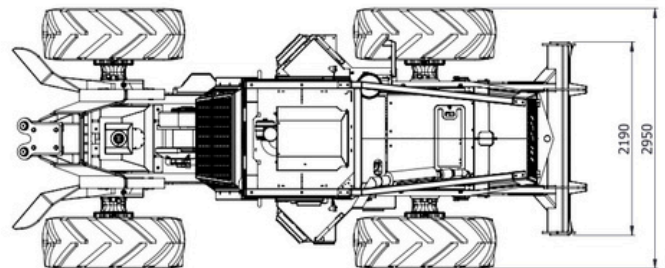
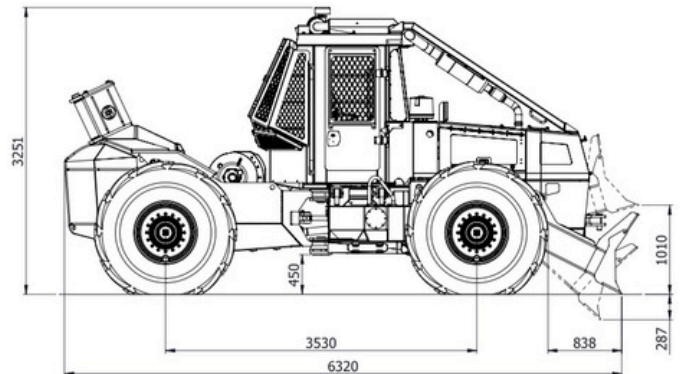

**BUILT AFRICA TOUGH**



**CALL : 0800 DEZZI / 33994**

Head Office: +27 (0)39-685 4100

Email: [machinesales@dezzi.co.za](mailto:machinesales@dezzi.co.za)

[www.dezzi.co.za](http://www.dezzi.co.za)