



D1700 WHEEL LOADER



BUILT AFRICA TOUGH

machinesales@dezzi.co.za

www.dezzi.co.za

D1700 WHEEL LOADER

SPECIFICATION SHEET

*Desmond Equipment SA (Pty) Ltd reserves the right to modify specifications without notice.

ENGINE

TYPE : Cummins
 MODEL : 6BT - 5.9 Turbocharged - FR90869 Tier 2
 CAPACITY : 5.9 Litres
 POWER : 130Hp (97KW) @ 2500 RPM
 TORQUE : 530Nm @ 1600 RPM

TRANSMISSION

TYPE : ZF
 MODEL : 4WG130
 • 4 Speed automatic/power shift transmission (modulated directional clutch)
 • Driven via converter from engine
 • Operation by single lever on left of steering wheel
 MAXIMUM SPEED IN GEARS : 4 Forward - 3 Reverse

	FIRST	SECOND	THIRD	FOURTH
FORWARD (km/h)	7.2	12.0	22.0	37.0
REVERSE (km/h)	7.7	12.0	24.0	-

AXLES

TYPE : ITL
 MODEL : PD87
 • Front axle fixed, rear axle oscillates through 12°
 • External planetary hub reduction and inboard wet sealed disc brakes
 • Limited-slip front and rear differentials

TYRES

STANDARD TYRES : 17.5 R25

BRAKES

SERVICE BRAKE
 • Inboard, sealed, wet brakes activating all four wheels
 • Fully hydraulically activated with fail safe
 • Brakes are activated by use of one brake pedal
PARK BRAKE
 • Mechanical type brake acting on the drive shaft
 • Operator engages manually

STEERING

• Centre pivot - frame articulation
 • Fully hydraulically powered with flow controlling system
 • Full flow filtering
 • Steering angle - 40° in each direction

ELECTRICS

VOLTAGE : 24 Volt
 BATTERY : 2 x 12 Volt
 ALTERNATOR : 24 Volt / 70 Amp

LOADER HYDRAULIC SYSTEM

• Closed system with pressure control
 • Fixed displacement gear type pump
 • Full flow filtering - Max flow 165 L/min

MAIN HYDRAULICS

• Two 139.7mm bore x 828mm stroke double acting cylinders
 • Working pressure - 2400 Psi

TILT HYDRAULICS

• Two 114.3mm bore x 617mm stroke double acting cylinders
 • Working pressure - 2 400 Psi

CAB

• Fully adjustable mechanical seat with arm rests
 • ROPS / FOPS Certified
 • Front Wipers
 • Roof-mounted ventilation fan with filters
 • OPTION - Air-conditioner with filters
 • Noise Level 85db

SERVICE CAPACITIES

COOLING SYSTEM : 32 Litres (50% anti-freeze)
 ENGINE CRANKCASE : 16 Litres
 DIFFERENTIALS : 28 Litres (per differential)
 TRANSMISSION : 26 Litres
 DIESEL TANK : 240 Litres
 HYDRAULIC SYSTEM : 185 Litres (Tank Only)
 210 Litres (Total System)
 PLANETARY HUB : 6 Litres (per planetary)

OPERATIONAL WEIGHTS

OPERATING WEIGHT : Front Axle : 4 600kg
 Rear Axle : 5 200kg
 Total : 9 800kg
 BREAKOUT FORCE : 10 320kg
 STATIC TIPPING LOAD : Straight : 6 748kg
 Full turn 40° : 5 972kg
 TURNING CIRCLE : 6 345mm radius outside bucket

BUCKET SPECIFICATIONS

GENERAL PURPOSE BUCKET : 1.7m³ / 1.9m³ (3 100kg Max)
 BUCKET WIDTH : 2 420mm

BUCKET CONTROLS

• Hydraulic, pilot operated by use of single lever joystick on right side of operator seat.

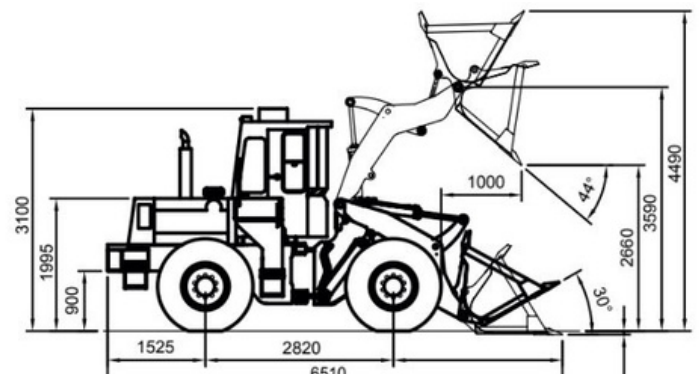

Machine width (mm) - 2420

BUILT AFRICA TOUGH



CALL : 0800 DEZZI / 33994

Head Office: +27 (0)39-685 4100

Email: machinesales@dezzi.co.za

www.dezzi.co.za