



DEZZI CMI 980 WHEEL LOADER



BUILT AFRICA TOUGH

machinesales@dezzi.co.za

www.dezzi.co.za



DEZZI CMI 980 WHEEL LOADER

SPECIFICATION SHEET

*Desmond Equipment SA (Pty) Ltd reserves the right to modify specifications without notice.

ENGINE

TYPE : John Deere
 MODEL : Tier III 6068HF485
 CAPACITY : 6.8 Litres
 POWER : 226Hp (168KW) @ 2200 RPM
 TORQUE : 1025Nm, @ 1400 RPM

TRANSMISSION

TYPE : ZF
 MODEL : Powershift
 • Full Auto-shift with automatic kick down

MAXIMUM SPEED IN GEARS : 4 Forward - 3 Reverse

	FIRST	SECOND	THIRD	FOURTH
FORWARD (km/h)	7	13	26	40
REVERSE (km/h)	7.3	13.7	27.3	-

AXLES

TYPE & MODEL: Front Axle : ZF MTL 3085 ||
 Rear Axle : ZF MTL 3095 ||
 • Front axle fixed, rear axle oscillates through 24°
 • Self adjusting high torque internal wet multi disc service brake
 • Limited-slip front and rear differentials

TYRES

STANDARD TYRES : 23.5 - 25

BRAKES

SERVICE BRAKE
 • Inboard, sealed, wet brakes activating all four wheels
 • Fully hydraulically activated with fail safe
 • Brakes are activated by use of one brake pedal
 PARK BRAKE
 • Mechanical type brake acting on the drive shaft
 • Operator engages manually

STEERING

• Centre pivot - frame articulation
 • Fully hydraulic-powered with flow controlling system
 • Full flow filtering
 • Steering angle - 40° in each direction

ELECTRICS

VOLTAGE : 24 Volt
 BATTERY : 2 x 12 Volt
 ALTERNATOR : 24 Volt / 70 Amp

LOADER HYDRAULIC SYSTEM

• Closed system with pressure control
 • Load sensing with axial piston pump
 • Full flow filtering - Max Flow 306 L/min

LIFT HYDRAULICS

• Two 160mm bore x 742mm stroke double acting cylinders
 • Working pressure - 2 400 Psi

TILT HYDRAULICS

• Single 180mm x 525mm stroke double-acting cylinder
 • Working pressure - 2 400 Psi

CAB

• Fully adjustable mechanical seat with arm rests
 • ROPS / FOPS Certified
 • Tilt adjustable steering column
 • Air-conditioner with filters
 • Fully-equipped instrument panel with visual and audible warnings

SERVICE CAPACITIES

COOLING SYSTEM : 40 Litres (50% Anti-freeze)
 ENGINE CRANKCASE : 19 Litres
 DIFFERENTIALS - FRONT : 35 Litres
 DIFFERENTIALS - REAR : 35 Litres
 TRANSMISSION : 27 Litres
 DIESEL TANK : 300 Litres
 HYDRAULIC SYSTEM : 150 Litres
 PLANETARY HUB : 6 Litres (per planetary)

OPERATIONAL WEIGHTS

OPERATING WEIGHT : Total - 19 500kg
 BREAKOUT FORCE : 187kN
 STATIC TIPPING LOAD : Straight - 15 739 kg
 Full turn 40° - 13 900kg
 TURNING CIRCLE : 6 830mm radius outside bucket

BUCKET SPECIFICATIONS

GENERAL PURPOSE BUCKET : 3.5m³
 BUCKET WIDTH : 3 000mm

BUCKET CONTROLS

• Hydraulic, pilot-operated by use of single lever joystick on right side of operator seat.
 • Bucket return-to-dig with automatic kickout

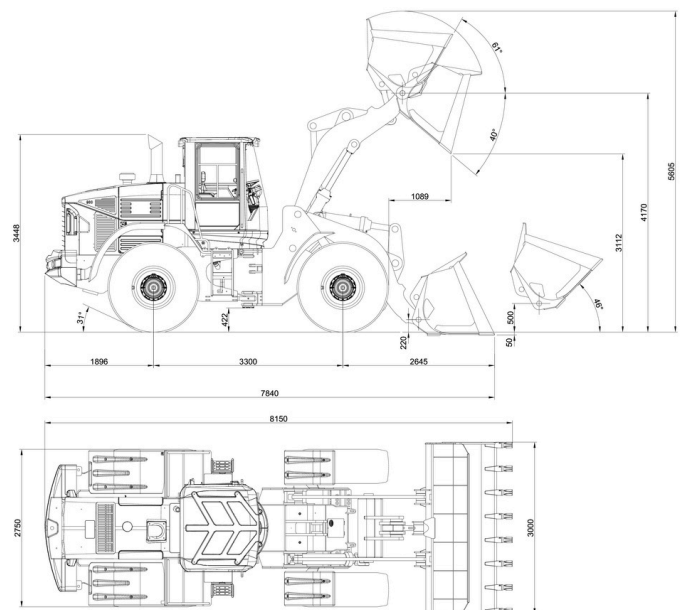

BUILT AFRICA TOUGH



CALL : 0800 DEZZI / 33994

Head Office: +27 (0)39-685 4100

Email: machinesales@dezzi.co.za

www.dezzi.co.za