



AH190B ARTICULATED HAULER



BUILT AFRICA TOUGH

machinesales@dezzi.co.za

www.dezzi.co.za



AH190B ARTICULATED HAULER

SPECIFICATION SHEET

*Desmond Equipment SA (Pty) Ltd reserves the right to modify specifications without notice.

ENGINE

TYPE : Cummins
 MODEL : QSB 260 - TIER 3. Turbocharged & intercooled
 CAPACITY : 6.7 Liters
 POWER : 260Hp (194KW) @ 2200 RPM
 TORQUE : 990 Nm @ 1500 RPM
 Approximate Fuel Burn : 12 - 14 Ltrs/Hr - Heavy Cycle
 10 - 12 Ltrs/Hr - Light Cycle

TRANSMISSION

TYPE : ZF
 MODEL : 6WG210
 GEARING : Constant mesh counter shaft with integral drop box.
 GEARS : Forward - 6
 Reverse - 3
 SPEED : 40Km/H
 TORQUE CONVERTER : Single phase 3 element, lock-up clutches effective in all gears. Downshift protection.

AXLES

FRONT & REAR : ZF MT-D 3095 axle - with self leveling air-ride suspension (front)

OPTIONAL : Rockwell (PRC673) with hypoid differential and external final drive planetary reduction; axles fixed with air ride suspension on front axle

TYRES

FRONT & REAR : 23.5 R25
 OPTIONAL : 620/75 R26

BRAKES

ALL 4 WHEELS : Sealed outboard wet disc brakes
 OPTIONAL : Rockwell - Air-operated S-cam failsafe drum brakes

FRAME

Heavy duty robust frame, front and rear with tube type oscillation, adjustable

STEERING

- Articulated with 40° steering angle either side
- Load-sensing, orbital-controlled
- Ground driven emergency steering

ELECTRICS

VOLTAGE : 24 Volt
 BATTERY : 2 x 12 Volt sealed type
 ALTERNATOR : 24 Volt / 70 Amp

HYDRAULIC SYSTEM

OIL CAPACITY : 170 Liters
 PUMPS : Variable displacement piston pump
 WORKING PRESSURE : Steering - 17 Mpa
 Tipping - 5 Mpa
 Full flow filtration

CAB

- ROPs and FOPs certified
- Trainer driver seat
- Beacon light & rear work lights
- Interior dome light
- Fully adjustable weight compensation suspension seat with seat belt
- Rubber mounted
- Air conditioner and tinted windows
- Dashboard with full instrumentation
- Windscreen wiper

PNEUMATIC SYSTEM

CAPACITY : 80 Liters
 WORKING PRESSURE : 120 Psi (8.1 Bar) with dual circuit unloader valve controlled system

SERVICE CAPACITIES

COOLING SYTEM : 50 Litres
 ENGINE CRANKCASE : 24 Litres
 REAR AXLE DIFFERENTIAL : 20 Litres
 TRANSMISSION : 18 Litres
 DIESEL TANK : 200 Litres

OPERATIONAL WEIGHTS

	Tare	Ballasted
TOTAL :	11 600kg	13 800kg
Front Axle :	7 700kg	7 700kg
Rear Axle :	3 900kg	6 100kg

STANDARD EQUIPMENT

- Emergency braking (rear)
- Hinged belly plate under engine
- Rear window guard
- Dash board with full instrumentation
- Air-conditioner
- Tinted windows

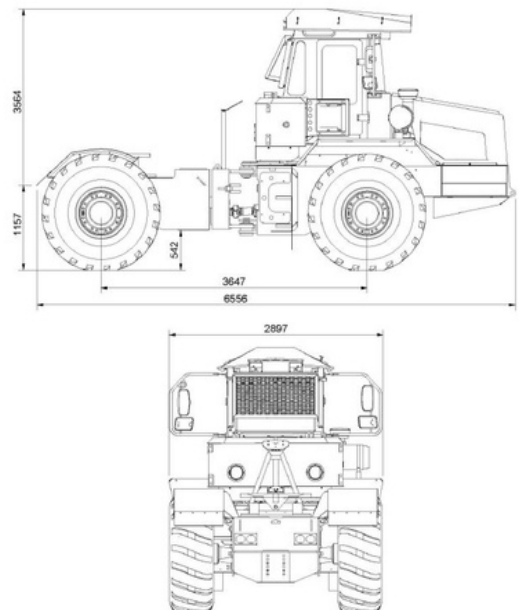

BUILT AFRICA TOUGH



CALL : 0800 DEZZI / 33994

Head Office: +27 (0)39-685 4100

Email: machinesales@dezzi.co.za

www.dezzi.co.za