



DEZZI D1200LP WHEEL LOADER



BUILT AFRICA TOUGH

Designed & Manufactured in South Africa

www.dezzi.co.za



DEZZI D1200LP WHEEL LOADER

SPECIFICATION SHEET

*Desmond Equipment SA (Pty) Ltd reserves the right to modify specifications without notice.

ENGINE

TYPE : JCB
 MODEL : 444T Turbocharged
 CAPACITY : 4.4 Litres
 POWER : 75kW @ 2400 RPM
 TORQUE : 425Nm @ 1300 RPM

TRANSMISSION

TYPE : ZF
 MODEL : 4WG130
 • Four speed power shift transmission with modulated directional clutch.
 • Driven via converter from engine.
 • With auto kick down
 MAXIMUM SPEED IN GEARS :

	FIRST	SECOND	THIRD	FOURTH
FORWARD (km/h)	4.9	10.6	15.6	25.0
REVERSE (km/h)	5.2	8.6	16.3	-

AXLES

TYPE : ITL
 MODEL : PD70
 • Front axle fixed, rear axle oscillates through 12°
 • Double reduction drives with standard differentials driving all four wheels

TYRES

STANDARD TYRES : 14.5 x 20 L3
 OPTIONAL TYRES : 335/80 R18

BRAKES

SERVICE BRAKE
 • Inboard, sealed, wet brakes activating all four wheels
 • Fully hydraulically activated with fail safe
 • Brakes are activated by use of one brake pedal
 PARK BRAKE
 • Mechanical type brake acting on the drive shaft
 • Operator engages manually

STEERING

• Centre pivot - frame articulation
 • Fully hydraulic-powered with flow controlling system
 • Full flow filtering
 • Steering angle - 35° in each direction

ELECTRICS

VOLTAGE : 12 Volt
 BATTERY : 21x 12 Volt
 ALTERNATOR : 12 Volt / 55 Amp

LOADER HYDRAULIC SYSTEM

• Closed system with pressure control
 • Fixed displacement gear type pump
 • Full flow filtering - Max flow 135 L/min

MAIN HYDRAULICS

• Two 114.3mm bore x 748.5mm stroke double acting cylinders
 • Working pressure - 2300 Psi

TILT HYDRAULICS

• Two 101.6mm bore x 420mm stroke double acting cylinders
 • Working pressure - 2 300 Psi

CAB

• Open station with roll bar

SERVICE CAPACITIES

COOLING SYSTEM : 28 Litres (50% anti-freeze)
 ENGINE CRANKCASE : 16 Litres
 DIFFERENTIALS : 12 Litres
 TRANSMISSION : 30 Litres
 DIESEL TANK : 180 Litres
 HYDRAULIC SYSTEM : 185 Litres (Tank only)
 200 Litres (Total System)
 PLANETARY HUB : 2.5 Litres (per planetary)

OPERATIONAL WEIGHTS

OPERATING WEIGHT : Front Axle - 3 800kg
 Rear Axle : 3 300kg
 Total - 7 100kg
 BREAKOUT FORCE : 8 270kg
 STATIC TIPPING LOAD : Straight - 6 347kg
 Full turn 35° - 6 140kg
 TURNING CIRCLE : 6 050mm radius outside bucket

BUCKET SPECIFICATIONS

GENERAL PURPOSE BUCKET : 0.9 m3
 BUCKET WIDTH : 2160 mm
 OPTIONAL EXTRAS : 1,2m3 GP

BUCKET CONTROLS

• Hydraulic, pilot operated by use of single lever joystick on right side of operator seat.

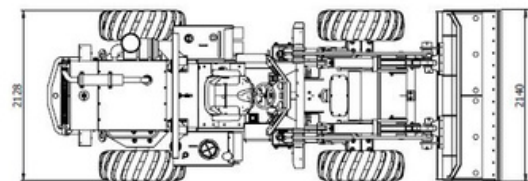
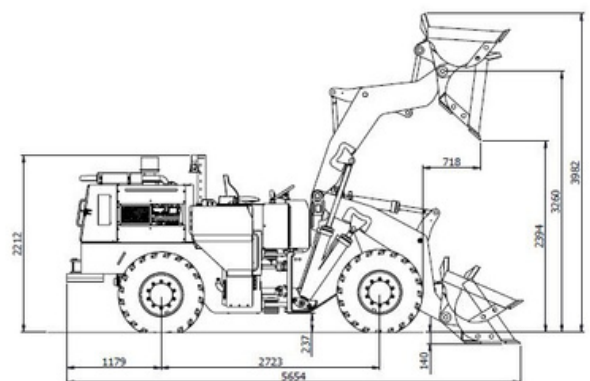

CALL : 0800 DEZZI / 33994
 Head Office: +27 (0)39-685 4100
 Email: machinesales@dezzi.co.za
 www.dezzi.co.za