



## DEZZI CMI 990 WHEEL LOADER



**BUILT AFRICA TOUGH**

[www.dezzi.co.za](http://www.dezzi.co.za)



# DEZZI CMI 990 WHEEL LOADER

## SPECIFICATION SHEET

\*Desmond Equipment SA (Pty) Ltd reserves the right to modify specifications without notice.

### ENGINE

TYPE : John Deere  
 MODEL : Tier III 6090HFC09  
 CAPACITY : 9.0 Litres  
 POWER : 224KW @ 2000 RPM  
 TORQUE : 1477Nm, @ 1600 RPM

### TRANSMISSION

TYPE : ZF  
 MODEL : Powershift  
 • Full Auto-shift with automatic kick down

MAXIMUM SPEED IN GEARS : 4 Forward - 3 Reverse

	FIRST	SECOND	THIRD	FOURTH
FORWARD (km/h)	7.3	12.1	18.6	40
REVERSE (km/h)	7.3	12.1	18.6	-

### AXLES

TYPE & MODEL : Front Axle : ZF MT-L 3105  
 MODEL : Rear Axle : ZF MT-L 3105  
 • Front axle fixed, real axle oscillates through 24°  
 • Self adjusting high torque internal wet multi disc service brake  
 • Limited-slip front and rear differentials

### TYRES

STANDARD TYRES : 26.5 - 25

### BRAKES

**SERVICE BRAKE**  
 • Inboard, sealed, wet brakes activating all four wheels  
 • Fully hydraulically activated with fail safe  
 • Brakes are activated by use of one brake pedal  
**PARK BRAKE**  
 • Mechanical type brake acting on the drive shaft  
 • Operator engages manually

### STEERING

• Centre pivot - frame articulation  
 • Fully hydraulic-powered with flow controlling system  
 • Full flow filtering  
 • Steering angle - 40° in each direction

### ELECTRICS

VOLTAGE : 24 Volt  
 BATTERY : 2 x 12 Volt  
 ALTERNATOR : 24 Volt / 100 Amp

### LOADER HYDRAULIC SYSTEM

• Closed system with pressure control  
 • Load sensing with axial piston pump  
 • Full flow filtering - Max flow 360 L/min

### LIFT HYDRAULICS

• Two 170mm bore x 840mm stroke double-acting cylinders  
 • Working pressure - 2400 Psi

### TILT HYDRAULICS

• Single 200 mm x 672mm stroke double-acting cylinder  
 • Working pressure - 2400 Psi

### CAB

• Fully adjustable mechanical seat with arm rests  
 • ROPS / FOPS Certified  
 • Tilt adjustable steering column  
 • Air-conditioner with filters  
 • Fully equipped instrument panel with visual and audible warnings

### SERVICE CAPACITIES

COOLING SYSTEM : 56 Litres (50% anti-freeze)  
 ENGINE CRANKCASE : 31 Litres  
 DIFFERENTIALS - FRONT : 42 Litres  
 DIFFERENTIALS - REAR : 42 Litres  
 TRANSMISSION : 32 Litres  
 DIESEL TANK : 400 Litres  
 HYDRAULIC SYSTEM : 60 Litres  
 PLANETARY HUB : 6 Litres (per planetary)

### OPERATIONAL WEIGHTS

OPERATING WEIGHT : Total - 25 400kg  
 BREAKOUT FORCE : 218 kN  
 STATIC TIPPING LOAD : Straight - 19 200kg  
 Full turn 40° - 16 950kg  
 TURNING CIRCLE : 7 250mm radius outside bucket

### BUCKET SPECIFICATIONS

GENERAL PURPOSE BUCKET : 4.5m<sup>3</sup>  
 BUCKET WIDTH : 3 200mm

### BUCKET CONTROLS

• Hydraulic, pilot-operated by use of single lever joystick on right side of operator seat.  
 • Bucket return-to-dig with automatic kickout

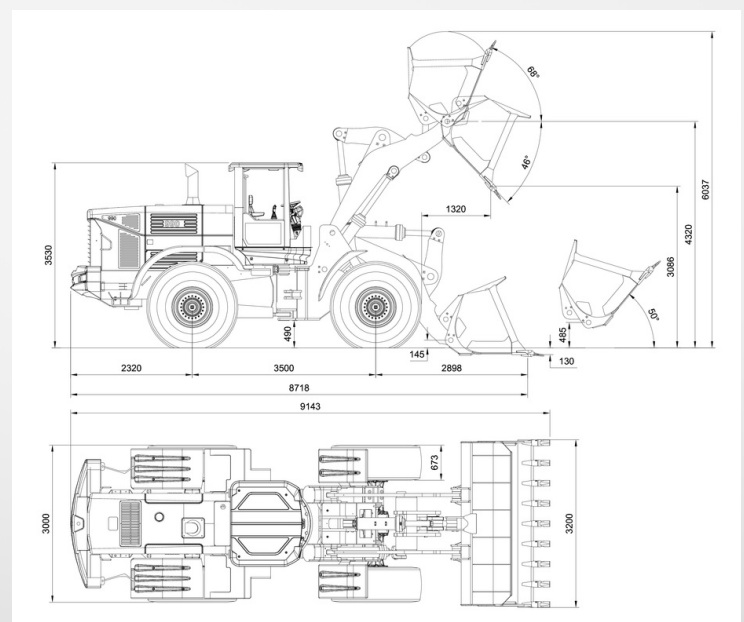

**BUILT AFRICA TOUGH**



CALL : 0800 DEZZI / 33994

Head Office: +27 (0)39-685 4100

Email: machinesales@dezzi.co.za

www.dezzi.co.za